

Fictitious Domain with Least-Squares Spectral Element Method to Explore Geometric Uncertainties by Chaos Collocation

Dr. Lucia Parussini and Dr. Valentino Pediroda

Mechanical Engineering Department

University of Trieste

Via A.Valerio, 10 – 34127 Trieste – ITALY

lparussini@units.it / pediroda@units.it

ABSTRACT

In this paper Chaos Collocation method coupled to Fictitious Domain approach has been applied to one- and two-dimensional elliptic problems defined on random domains in order to demonstrate the accuracy and convergence of the methodology. Chaos Collocation method replaces a stochastic process with a set of deterministic problems, which can be separately solved, so that the big advantage of Chaos Collocation is that it is non-intrusive and existing deterministic solvers can be used. For the analysis of differential problems obtained by Chaos Collocation, Fictitious Domain method with Least-Squares Spectral Element approximation has been employed. This algorithm exploits a fictitious computational domain, where the boundary constraints, immersed in the new simple shaped domain, are enforced by means of Lagrange multipliers. For this reason its main advantage lies in the fact that only a Cartesian mesh, that represents the enclosure, needs to be generated. Excellent accuracy properties of developed method are demonstrated by numerical experiments.

1.0 INTRODUCTION

In most engineering applications, to solve physical problems deterministic mathematical models are adopted. It is evident these models are rough simplifications of reality. Actually, many physical input parameters are not deterministic entities, but stochastic processes which certainly influence the behaviour of solution. In order to obtain reliable results uncertainty quantification is necessary and the influence of inherent physical and geometric uncertain parameters must not be neglected. Thanks to the increasing of computer facilities and the advance of algorithms, which leads to more accurate solutions, the current state of technology allows including these inherent uncertainties in mathematical models.

There have been an increasing interest in uncertainty analysis applied to computational physics and probabilistic methods have been developed. These methods for uncertainty quantification can be divided into two main categories: non-intrusive, or statistical, and intrusive, or non-statistical. Monte Carlo [3], Stochastic Collocation [16], Chaos Collocation [13] are examples of non-intrusive approaches, Chaos Polynomials [34][36] are examples of intrusive approaches. Non-intrusive methods allow the use of existing deterministic solvers, whereas intrusive approaches need to modify the solver obtaining an efficient tool but limited to solve just a set of problems.

In literature there are several examples of numerical methods to face problems with uncertain input parameters and in [14][30][33][34][35] we find applications of these methodologies to thermo-fluid dynamics. In these works the effort is focused on exploring random material properties or random boundary conditions, whereas the topology of domain boundaries are described in deterministic terms, without taking in account of their stochastic nature (Figure 1).

Parussini, L.; Pediroda, V. (2007) Fictitious Domain with Least-Squares Spectral Element Method to Explore Geometric Uncertainties by Chaos Collocation. In *Computational Uncertainty in Military Vehicle Design* (pp. 36-1 – 36-28). Meeting Proceedings RTO-MP-AVT-147, Paper 36. Neuilly-sur-Seine, France: RTO. Available from: <http://www.rto.nato.int>.

Fictitious Domain with Least-Squares Spectral Element Method to Explore Geometric Uncertainties by Chaos Collocation

On the contrary there are really few examples of numerical methods to analyse geometric uncertainty, which means to solve deterministic problems, in terms of material properties and boundary constraints, on random domains (Figure 2), with geometric uncertainty given by shape tolerance.

In [11][36], geometric uncertainty pertains to roughness, which is an important thermo-fluid dynamic parameter. In particular [11] presents an analytical model to study the roughness in supersonic flow and the analytical results are compared with several Polynomial Chaos methodologies, such as mapping, Stochastic Collocation and Sparse Grid. In [36] the fluid dynamics in rough channels is studied using a mapping methodology. The obtained results confirm Chaos methods are suitable to study geometric uncertainty given roughness.

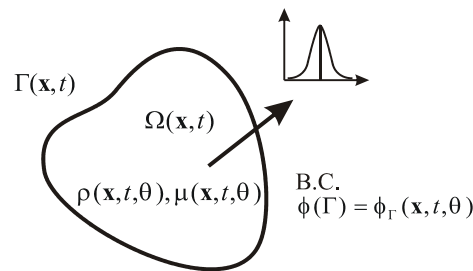

Figure 1: Differential problem with stochastic material properties and stochastic boundary conditions, where θ is uncertainty.

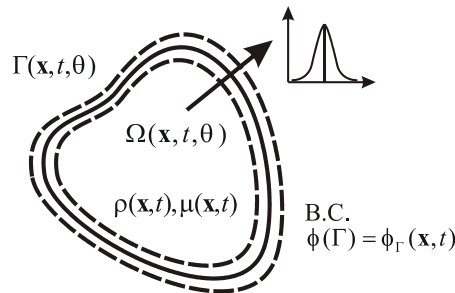

Figure 2: Differential problem with stochastic definition domain, where θ is uncertainty.

Another interesting topic pertaining to geometric uncertainty is the study of shape tolerance and its interaction with the state problem. In [8] the influence of geometric tolerance on fluid dynamic field is shown, referring to an angle. A Chaos methodology is used to explore the random domain, in particular a non-intrusive approach.

In this work we present a method to face geometric tolerance problems, which allows avoiding the limitations of previous referred methodologies, in particular both the difficulty of mapping space variables into a deterministic domain and the need to remesh the geometry of domain.

Pursuing this purpose, we present a new method based on the coupling of Chaos Collocation method and Fictitious Domain approach. According to Generalized Polynomial Chaos theory, a stochastic process can be expressed as a spectral expansion based on suitable orthogonal polynomial with weights associated with a particular density. For non-intrusive approach, a Collocation projection is applied in the random dimension and the resulting system of deterministic equations is then solved to obtain the solution for each random node of nodal approximation. The important advantage of using a non-intrusive method is there is no need to modify the solver of deterministic equations, simplifying the management of computational process.

To solve the deterministic problem Least Squares Spectral Element Method is used [4][19][20][21][22][23]. Moreover a Fictitious Domain approach is adopted, introducing more benefits to methodology.

Fictitious Domain methods allow problems formulated on an intricate domain Ω to be solved on a simpler domain Π containing Ω . The extension of original problem to fictitious region Π/Ω must be chosen so that the solution of extended problem restricted to Ω coincides with the solution of original problem. There are several approaches to implement Fictitious Domain: Elimination method [37], Penalty method [24][37], Distributed Lagrangian method [5][6][7], Boundary Lagrangian method [9][29], Fat Boundary method [17]. A technique which is popular, given its efficiency, is to enforce the boundary conditions by Lagrange multipliers, which is the method we propose in this paper. The main motivation for Fictitious Domain approach is that, defining the extended problem on a simple domain, enables the use of efficient discretization methods on simple structured grids. In this way the solution of state problem is independent by small variations of domain Ω subject to uncertainty and contained into computational domain Π , which is independent by random geometric parameters. Thereby an evident further advantage of the method is that the remeshing of computational domain for each random node solution has no more to be performed.

The excellent accuracy of proposed methodology, Chaos Collocation method and Fictitious Domain with Least-Squares Spectral Element approximation, is demonstrated by numerical experiments.

The paper is organized as follows. In Section 2.0 some details are given about uncertainty quantification methods. In Section 3.0 the approaches to face problems with geometric uncertainties are discussed. In Section 4.0 the Fictitious Domain method is illustrated and its good accuracy properties are demonstrated by numerical experiments. In Section 5.0 the formulation of Chaos Collocation Method with Fictitious Domain approach is explained and in Section 6.0 some numerical examples to validate the Chaos Collocation Method with Fictitious Domain approach are shown. In Section 7.0 we give some concluding remarks.

2.0 UNCERTAINTY QUANTIFICATION METHODS

2.1 Setting of the problem: stochastic differential equation

In this section the Generalized Polynomial Chaos is explained in order to solve the following stochastic differential equation:

$$L(\mathbf{x}, t, \theta; \phi) = f(\mathbf{x}, t, \theta) \quad (1)$$

where L is a differential operator which contains space and time differentiation and can be non linear and depended on random parameters θ , $\phi(\mathbf{x}, t, \theta)$ is the solution and function of the space $\mathbf{x} \in \mathcal{R}^d$, time t and random parameters θ ; $f(\mathbf{x}, t, \theta)$ is a space, time and random parameters dependent source term.

2.2 The Generalized Polynomial Chaos

Under specific conditions [28], a stochastic process can be expressed as a spectral expansion based on suitable orthogonal polynomial with weights associated with a particular density. The first study in this field is the Wiener process [31][32], which can be written as a spectral expansion in terms of Hermite polynomials with normal distributed input parameters.

The basic idea is to project the variables of the problems on a stochastic space modelled by a set of eigenfunctions Ψ that depend on random variables $\xi(\theta)$, where θ is the random event. For example, the variable ϕ has the following spectral finite dimensional representation:

Fictitious Domain with Least-Squares Spectral Element Method to Explore Geometric Uncertainties by Chaos Collocation

$$\phi(\mathbf{x}, t, \theta) = \sum_{i=0}^{\infty} \phi_i(\mathbf{x}, t) \Psi_i(\xi(\theta)) \quad (2)$$

In practical terms the Eq.(2) divides the random variables $\phi(\mathbf{x}, t, \theta)$ into a deterministic part, the coefficient $\phi_i(\mathbf{x}, t)$, and a stochastic part, the polynomial chaos $\Psi_i(\xi(\theta))$.

The basis $\{\Psi_i\}$ is a set of orthogonal polynomials with respect to the probability density function of the input parameters. Following the Askey scheme [2], it is possible to introduce the Generalized Polynomial Chaos [35]; thanks to this theory, known also as *Askey-chaos*, for certain input parameter distribution there exist the best representation in terms of convergence rate. For example, for Gaussian random input, we have the Hermite Polynomial Chaos representation, for Gamma distribution the Laguerre representation, for Beta distribution the Jacoby representation, for Uniform distribution the Legendre representation, etc.

In this paper we focus mainly on Gaussian random input, so we represent the variable $\phi(\mathbf{x}, t, \theta)$ in terms of Hermite spectral representation (following the Askey terms):

$$\begin{aligned} \phi(\mathbf{x}, t, \theta) = & \phi_0(\mathbf{x}, t) H_0 + \sum_{i_1=1}^{\infty} \phi_{i_1}(\mathbf{x}, t) H_1(\xi_{i_1}(\theta)) + \\ & \sum_{i_1=1}^{\infty} \sum_{i_2=1}^{i_1} \phi_{i_1 i_2}(\mathbf{x}, t) H_2(\xi_{i_1}(\theta), \xi_{i_2}(\theta)) + \sum_{i_1=1}^{\infty} \sum_{i_2=1}^{i_1} \sum_{i_3=1}^{i_2} \phi_{i_1 i_2 i_3}(\mathbf{x}, t) H_3(\xi_{i_1}(\theta), \xi_{i_2}(\theta), \xi_{i_3}(\theta)) + \dots \end{aligned} \quad (3)$$

where $H_p(\xi_{i_1}, \dots, \xi_{i_p})$ is the Hermite polynomial of order p in terms of a n -dimensional Gaussian random variable $\xi = (\xi_1, \dots, \xi_n)$ distributed as $N(0,1)$.

The Hermite polynomial is expressed in general form by:

$$H_p(\xi_{i_1}, \dots, \xi_{i_p}) = e^{\frac{1}{2}\xi^T \xi} (-1)^p \frac{\partial^p}{\partial \xi_{i_1} \dots \partial \xi_{i_p}} e^{-\frac{1}{2}\xi^T \xi} \quad (4)$$

and for one-dimensional case:

$$H_0 = 1, \quad H_1 = \xi, \quad H_2 = \xi^2 - 1, \quad H_3 = \xi^3 - 3\xi, \quad \dots \quad (5)$$

For practical cases, the series has to be truncated to a finite numbers of terms, here denoted with N . So the form Eq.(2), using the one-to-one correspondence between the function $H_p(\xi_{i_1}, \dots, \xi_{i_p})$ and $\Psi_p(\xi)$ as demonstrating in [33] for Gaussian random input, becomes:

$$\phi(\mathbf{x}, t, \theta) = \sum_{i=0}^N \phi_i(\mathbf{x}, t) H_i(\xi) \quad (6)$$

The number of total terms of the series is determined by:

$$N + 1 = \frac{(n + p)!}{n! p!} \quad (7)$$

where n is the uncertainties dimensionality and p is the expansion order.

As an example, for a second order 2-D Hermite polynomial expression, we get the following form:

$$\begin{aligned} \phi(\mathbf{x}, t, \theta) = & \phi_0(\mathbf{x}, t) + \\ & \phi_1(\mathbf{x}, t)\xi_1(\theta) + \phi_2(\mathbf{x}, t)\xi_2(\theta) + \\ & \phi_3(\mathbf{x}, t)(\xi_1^2(\theta) - 1) + \phi_4(\mathbf{x}, t)(\xi_2^2(\theta) - 1) + \phi_5(\mathbf{x}, t)\xi_1(\theta)\xi_2(\theta) \end{aligned} \quad (8)$$

where $\xi_1(\theta)$ and $\xi_2(\theta)$ are the two random independent variables.

2.3 Chaos Polynomial and Chaos Collocation

Substituting the Polynomial Chaos series, given in Eq.(6) for Gaussian random input, into the stochastic differential Eq.(1) we obtain:

$$L\left(\mathbf{x}, t, \theta; \sum_{i=0}^N \phi_i(\mathbf{x}, t)\Psi_i(\xi(\theta))\right) \cong f(\mathbf{x}, t, \theta) \quad (9)$$

The method of Weighted Residuals is adopted to solve this equation. The coefficients $\phi_i(\mathbf{x}, t)$ are obtained imposing the inner product of the residual with respect to a weight function is equal to zero.

If the weight functions are chosen to be the same as the expansion functions Ψ_i we produce Galerkin method. Performing the Galerkin projection on both sides of the equation, the form becomes:

$$\left\langle L\left(\mathbf{x}, t, \theta; \sum_{i=0}^N \phi_i(\mathbf{x}, t)\Psi_i\right), \Psi_j \right\rangle = \langle f(\mathbf{x}, t, \theta), \Psi_j \rangle \quad j = 0, \dots, N. \quad (10)$$

If the operator L is non linear, the deterministic set of $N + 1$ equation is coupled and this intrusive form is called *Chaos Polynomial*.

If we employ Dirac delta function as weight function we produce Collocation method. Using a Collocation projection on both sides of Eq.(9), we obtain:

$$L(\mathbf{x}, t, \theta_j; \phi) = f(\mathbf{x}, t, \theta_j) \quad j = 0, \dots, N. \quad (11)$$

This formulation is a linear system equivalent to solving a deterministic problem at each grid point; this non-intrusive form is called *Chaos Collocation*.

To reconstruct the stochastic solution $\phi(\mathbf{x}, t, \theta)$, the Eq.(2) is used:

$$E_{PC}(\phi) = \mu_\phi = \phi_0(\mathbf{x}, t) \quad (12)$$

$$Var_{PC}(\phi) = \sigma_\phi^2 = \sum_{i=1}^N \phi_i^2(\mathbf{x}, t) \langle \Psi_i^2 \rangle \quad (13)$$

Fictitious Domain with Least-Squares Spectral Element Method to Explore Geometric Uncertainties by Chaos Collocation

Here

$$\langle \Psi_i, \Psi_j \rangle = \langle \Psi_i^2 \rangle \delta_{ij} = \frac{1}{\sqrt{2\pi}} \int_{-\infty}^{+\infty} e^{-\xi^2/2} \Psi_i(\xi) \Psi_j(\xi) d\xi = 2^i i! \delta_{ij} \quad (14)$$

where δ_{ij} is the Kronecker operator.

The two approaches are based on the same theory, but gives different numerical representations. In practice intrusive Chaos Polynomial method consists in resolution of a coupled system of deterministic equations, non-intrusive Chaos Collocation method consists in resolution of a decoupled system of deterministic equations. It is evident the difficulty to design an efficient intrusive solver, both because of computational cost and because of the obvious handicap to imply an internal modification of the deterministic solver [12]. The non-intrusive methodology has a simpler computational management. A remarkable advantage of this approach is the deterministic solver represents a black-box and there is no need to modify it. This means the non-intrusive method is more versatile than intrusive method.

A still open problem of Chaos Collocation approach [14] is the difficulty to select collocation points: with multi dimensional uncertainties the choice is not unique [8]. This problem does not exist for one stochastic parameter, because collocation points are the roots of polynomial of order $p + 1$.

In this paper we focus our attention on geometric tolerances employing Chaos Collocation method and Fictitious Domain approach. As the goal is a better comprehension of the problem, for sake of simplicity we will just consider one uncertain parameter with Gaussian distribution, using Hermite polynomials for expansion. In this way we avoid the difficulty of arbitrary choice of collocation points for multi dimensional non-intrusive method.

3.0 GEOMETRIC UNCERTAINTIES

The uncertainty we want to examine is due to geometric tolerance. In this case the geometry of definition domain is a stochastic phenomenon. The problem under study, as defined in [36], writes:

Let $\theta \in \Theta$ be a random realization drawn from a complete probability space (Θ, A, P) , whose event space Θ generates its σ -algebra $A \subset 2^\Theta$ and is characterized by a probability measure P . For all $\theta \in \Theta$, let $\Omega(\theta) \subset \mathbb{R}^d$ be a d -dimensional random domain bounded by boundary $\partial\Omega(\theta)$. We consider the following stochastic boundary value problem: for P -almost everywhere in Θ , given $f : \Omega(\theta) \rightarrow \mathbb{R}$ and $g : \Omega(\theta) \rightarrow \mathbb{R}$, find a stochastic solution $v : \bar{\Omega}(\theta) \rightarrow \mathbb{R}$ such that:

$$\begin{aligned} A(\mathbf{x}; v) &= f(\mathbf{x}) && \text{in } \Omega(\theta) \\ B(\mathbf{x}; v) &= g(\mathbf{x}) && \text{on } \partial\Omega(\theta) \end{aligned} \quad (15)$$

where $\mathbf{x} = (x_1, \dots, x_d)$, A is a differential operator and B is a boundary operator.

Except for a few studies, random domain problems have not been systematically analyzed. The most complete work on these topics is presented in [36], where a mapping methodology is introduced to transform the original problem defined in a random domain into a stochastic problem defined in a deterministic domain. In particular a one-to-one mapping function and its inverse are established: $\xi = \xi(\mathbf{x}, \theta)$ and $\mathbf{x} = \mathbf{x}(\xi, \theta)$, which transforms the random domain $\Omega(\theta) \subset \mathbb{R}^d$ into a deterministic

domain $\omega \subset \mathfrak{R}^d$, whose coordinates are denoted as $\xi = (\xi_1, \dots, \xi_d)$. I.e., for P -almost everywhere $\theta \in \Theta$, $\mathbf{x} \in \Omega(\theta) \leftrightarrow \xi \in \omega$. The stochastic mapping transforms the deterministic differential operators A and B into their stochastic counterparts \mathcal{A} and \mathcal{B} , respectively, and the random domain problem into the following stochastic boundary-value problem. For P -almost everywhere $\theta \in \Theta$, given $f : \omega \times \Theta \rightarrow \mathfrak{R}$ and $g : \omega \times \Theta \rightarrow \mathfrak{R}$, find a stochastic solution $u : \bar{\omega} \times \Theta \rightarrow \mathfrak{R}$ such that

$$\begin{aligned} \mathcal{A}(\xi, \theta; u) &= f(\xi, \theta) && \text{in } \omega \\ \mathcal{B}(\xi, \theta; u) &= g(\xi, \theta) && \text{on } \partial\omega \end{aligned} \tag{16}$$

where f and g are the transformed functions of f and g , respectively.

This methodology has been efficiently implemented to solve two diffusion problems: in a channel with rough surface and in double-connected domains with rough exclusion. The drawback of the presented method is the difficulty of mapping. In fact this process is simple for connected domains, but it is computationally challenging for complex non-connected domains.

To ride over this problem, i.e. the mapping of complex domains, in this work we present the coupling of Chaos Collocation method and Fictitious Domain approach for geometric uncertainties. The idea is to avoid the mapping of stochastic domain onto a deterministic domain and to use absolute coordinates, so that the geometric uncertainty becomes an uncertainty on the position of boundary condition.

As an example, let us consider the following problem:

$$\begin{aligned} \frac{d^2\phi}{dx^2} + k\phi &= 0 && \text{in } [0, L] \\ \text{with } \left. \frac{d\phi}{dx} \right|_{x=0} &= q_0 && \text{and } \left. \frac{d\phi}{dx} \right|_{x=L} = k\phi(L) \end{aligned} \tag{17}$$

where $k = -10^{-5}$, $\phi_0 = 0.001$, $L = N(100, 1)$.

Eq.(17) is a stochastic domain problem where the length L of domain has a normal distribution with mean equal to 100 and variance equal to 1.

If we adopt the mapping method presented in [36], Figure 3 shows this approach referred to problem Eq.(17). The stochastic mapping of $\Omega(\theta) = [0, L]$ onto $\omega = [0, 1]$ is constructed via solution of Laplace equations:

$$\frac{\partial^2 x}{\partial \xi^2} = 0 \quad \text{in } \omega \quad \text{with } x(0) = 0 \quad \text{and } x(1) = L \tag{18}$$

and the new stochastic problem defined on a deterministic domain, thanks to this mapping, can be solved by already existing Polynomial Chaos techniques.

Fictitious Domain with Least-Squares Spectral Element Method to Explore Geometric Uncertainties by Chaos Collocation

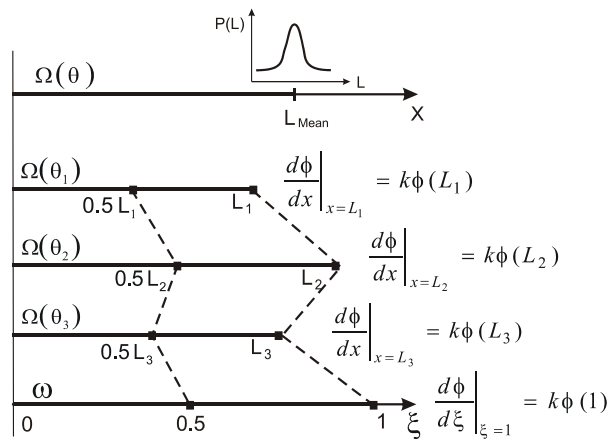

Figure 3: Stochastic domain problem Eq.(17) with normal distribution of length L . Illustration of mapping technique.

Figure 4 shows our approach, where geometric uncertainty, represented by probabilistic distribution $P(L)$ of domain length L , becomes an uncertainty on the position of boundary condition. Therefore there is no need of mapping the stochastic domain onto a deterministic domain: every point of domain is studied in absolute coordinates. The solution of the problem has a probability distribution $pdf(\phi)$ associated to each point of domain in absolute coordinates. This probability distribution of the solution depends on the position of boundary condition in $x = L$, which is a stochastic phenomenon. Obviously each point has a probability $P(x)$ of belonging to domain, as shown in Figure 4, which depends on the probabilistic distribution of L .

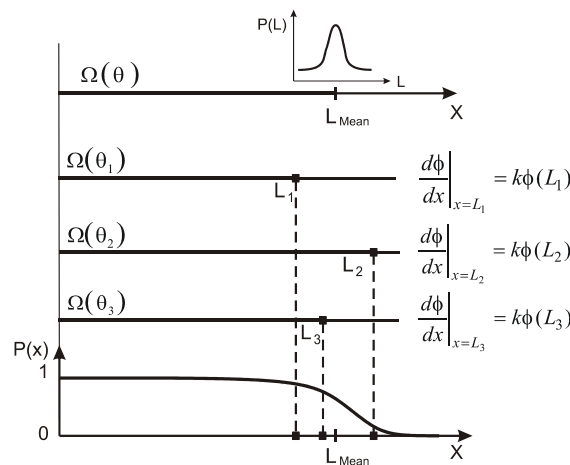

Figure 4: Stochastic domain problem Eq.(17) with normal distribution of length L . Illustration of our approach using absolute coordinates.

To find the solution of stochastic problem Eq.(17), exploiting the Chaos Collocation approach given in Eq.(11), we have to solve N distinct deterministic problems defined on different lengths of domain.

It could be remarked the drawback of our method is the need to modify the computational domain for every different simulation. So, if we can not solve analytically the differential equations, we have to remesh the computational domain for each new simulation and the difficulty to have an accurate grid for

every geometry is well-known. To avoid this problem we introduce Fictitious Domain methodology, so that the stochastic domain does not coincide with the computational domain, which is the same for all simulations. The boundary conditions, immersed in the computational domain, are enforced by means of Lagrange multipliers and for each new geometry there is no need to modify the computational grid but just to recompute the data related to immersed boundaries.

4.0 FICTITIOUS DOMAIN VIA LAGRANGE MULTIPLIERS WITH LEAST-SQUARES SPECTRAL ELEMENT METHOD

4.1 Fictitious Domain approach

Fictitious domain approach allows solving easily differential problems defined on domain changing in time and space, i.e. in general structural elastic problems, fluid dynamics problems with moving rigid bodies, shape optimization problems, and so on. This means the same problem is solved on different domains.

In general to front these problems the boundary variation technique is used, based on a sequence of domains (Figure 5). Using a method based on domain discretization, such as finite element method, spectral elements, finite volumes, after the shape variation the computational domain has to be remeshed, the data of state problem have to be recompute and the update problem has to be solved. It is evident this requires high computing time. Moreover it is difficult to find a partition of domain such that grid quality is good for every domain.

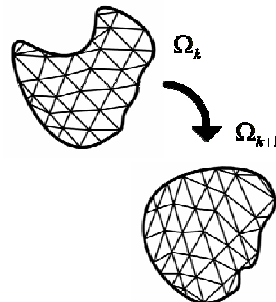

Figure 5: Classical approach based on the boundary variation technique to solve differential problems defined on domain changing in time and space.

In this case it is useful to consider a Fictitious Domain approach (Figure 6), where computational domain is not the same of definition domain, but it contains that one, so when the definition domain changes the computational domain does not change with evident advantages. The need of such kind of tool is confirmed by experience.

Several variants of Fictitious Domain method exist: the basic idea is to extend the operator and the domain into a larger simple shaped domain. The most important ways to do this are algebraic and functional analytic approaches. In algebraic Fictitious Domain methods the problem is extended typically at algebraic level in such a way that the solution of original problem is obtained directly as a restriction of the solution of extended problem without any additional constraint. There are several variants of such an approach [15][26] and they can be rather efficient, but typically they are restricted to quite a narrow class of problems.

Fictitious Domain with Least-Squares Spectral Element Method to Explore Geometric Uncertainties by Chaos Collocation

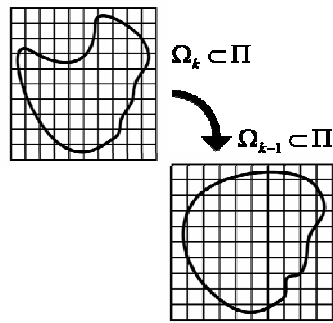

Figure 6: Fictitious Domain approach to solve differential problems defined on domain changing in time and space.

More flexibility and better efficiency can be obtained by using a functional analytic approach where the use of constraints ensures that the solution of extended problem coincides with the solution of original problem. In our implementation we enforce constraints by Lagrange multipliers [18].

The physical aspects of the problem can always be stated in a variational principle form. A variational principle specifies a scalar quantity, the functional J , which is defined by an integral form

$$J = \int_{\Omega} F\left(\phi, \frac{\partial \phi}{\partial x}, \frac{\partial \phi}{\partial y}, \dots, x, y, \dots\right) d\Omega + \int_{\Gamma} E\left(\phi, \frac{\partial \phi}{\partial x}, \frac{\partial \phi}{\partial y}, \dots, x, y, \dots\right) d\Gamma \quad (19)$$

in which $\Gamma = \partial\Omega$, ϕ is the unknown function and F and E are specified operators. The solution to the continuum problem is a function ϕ which make J stationary with respect to small changes $\delta\phi$; thus, for a solution to the continuum problem, the variation is $\delta J = 0$.

To implement the Fictitious Domain approach we have to extend the operator F and the domain Ω into a larger simple shaped domain Π and to constrain the functional on $\Gamma = \partial\Omega$ (Figure 7). To treat such problems Lagrangian multipliers are introduced, so that the problem is now equivalent to find the stationary point of J' , where

$$J' = \int_{\Pi} F\left(\phi, \frac{\partial \phi}{\partial x}, \frac{\partial \phi}{\partial y}, \dots, x, y, \dots\right) d\Omega + \int_{\Gamma} \lambda(\mathbf{x}) E\left(\phi, \frac{\partial \phi}{\partial x}, \frac{\partial \phi}{\partial y}, \dots, x, y, \dots\right) d\Gamma. \quad (20)$$

Here $\lambda(\mathbf{x})$ is an undetermined multiplier which is in general a function of position, because the local condition must be satisfied at every point of Γ , rather than being a global restriction.

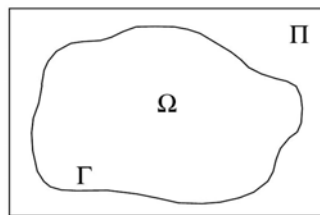

Figure 7: Example of a fictitious rectangular domain Π containing the original domain Ω . Π represents the computational domain, Ω is the definition domain of the state problem.

New approach, we present in this paper, is the coupling of Fictitious Domain together with a high order method. To discretize the problem under study we use the Least Squares Spectral Element Method, based on higher order functions, locally defined over finite size parts of domain. The Least Squares Spectral Element Method (**LSQSEM**) combines the least squares formulation with a spectral element approximation. This provides several advantages. The method produces symmetric positive definite linear systems for every type of partial differential equation, i.e. elliptic, parabolic and hyperbolic equations. No compatibility requirements need to be imposed between approximating function spaces for mixed problems. The method converges just as fast with hp refinement than conventional Galerkin methods. Furthermore, no stabilization is required for convection dominated flows. Moreover using Fictitious Domain approach, where extended problem is defined on a simple domain, enables the use of efficient computational grids, in our case just simple Cartesian grids.

Good accuracy properties of the method are demonstrated by numerical experiments.

4.2 Least-Squares variational principle

Let $\bar{\Omega}$ be the closure of an open bounded region Ω in \mathcal{R}^d , where d represents the number of space dimensions, and let $\mathbf{x} = (x_1, \dots, x_d)$ be a point in $\bar{\Omega} = \Omega \cup \partial\Omega$, where $\partial\Omega = \Gamma$ is the boundary of Ω . We consider the model problem stated as follows:

Find $\phi(\mathbf{x})$ such that

$$\begin{aligned} -\Delta\phi &= f & \text{in } \Omega(\theta) \\ \phi &= \phi_s & \text{on } \Gamma(\theta) \end{aligned} \tag{21}$$

where f is the source term and ϕ_s is the prescribed value of ϕ on boundary Γ . This problem is chosen only for notational simplicity; our statements are also valid for every type of deterministic differential problem, i.e. elliptic, parabolic and hyperbolic equations.

Although direct application of the least squares variational principles to Eq.(21) is possible, it will result in an impractical least squares finite element model, as these have associated with them the requirement of higher regularity of the finite element spaces. The degree of necessary smoothness is dictated by the differentiability requirements of the governing equation under consideration. Moreover, the resulting condition number of the corresponding discrete problem would be much higher compared with the condition number resulting from application of the weak form Galerkin method to the same problem.

To reduce the higher regularity requirements, the governing equations are first transformed into an equivalent first-order system. Transformation of the governing equations to an equivalent first-order system necessarily implies that additional independent variables need be introduced, implying an increase in cost. However, the auxiliary variables may be argued to be beneficial as they may represent physically meaningful variables, e.g. fluxes, and will be directly approximated in the model.

We proceed by replacing the problem, Eq.(21), with its first-order equivalent system:

Find $\phi(\mathbf{x})$ and $\mathbf{q}(\mathbf{x})$ such that

**Fictitious Domain with Least-Squares Spectral Element
Method to Explore Geometric Uncertainties by Chaos Collocation**

$$\begin{aligned}
-\nabla \cdot \mathbf{q} &= f && \text{in } \Omega(\theta) \\
\nabla \phi - \mathbf{q} &= 0 && \text{in } \Omega(\theta) \\
\nabla \times \mathbf{q} &= 0 && \text{in } \Omega(\theta) \\
\phi &= \phi_s && \text{on } \Gamma(\theta)
\end{aligned} \tag{22}$$

where \mathbf{q} is a vector valued function whose components are the fluxes of scalar function ϕ , as defined in second Eq.(22). Third Eq.(22) is a curl constraint to ensure H^1 -coercivity of the system.

For $s \geq 0$, we use the standard notation and definition for the Sobolev spaces $H^s(\Omega)$ and $H^s(\Gamma)$ with corresponding inner products denoted by $(\cdot, \cdot)_{s, \Omega}$ and $\langle \cdot, \cdot \rangle_{s, \Gamma}$ and norms by $\|\cdot\|_{s, \Omega}$ and $\|\cdot\|_{s, \Gamma}$, respectively. We denote the $L_2(\Omega)$ and $L_2(\Gamma)$ inner products by $(\cdot, \cdot)_{\Omega}$ and $\langle \cdot, \cdot \rangle_{\Gamma}$, respectively. By $\mathbf{H}^s(\Omega)$ we denote the product space $[H^s(\Omega)]^d$.

In the least-squares approach, the variational problem is such that the function ϕ and its flux \mathbf{q} minimize the sum of the squares of the residuals of the governing equations measured in the L_2 norm. The associated functional is given by

$$J(\phi, \mathbf{q}; f) = \frac{1}{2} \|\nabla \cdot \mathbf{q} - f\|_{0, \Omega}^2 + \frac{1}{2} \|\nabla \phi - \mathbf{q}\|_{0, \Omega}^2 + \frac{1}{2} \|\nabla \times \mathbf{q}\|_{0, \Omega}^2. \tag{23}$$

According to Fictitious Domain methodology the problem will be extended to a simple shaped domain $\Pi \supset \Omega$ with immersed constraints enforced via Lagrange multipliers.

So the new functional associated with the equivalent Fictitious Domain problem will be:

$$J(\phi, \mathbf{q}, \lambda; f, \phi_s) = \frac{1}{2} \|\nabla \cdot \mathbf{q} - f\|_{0, \Pi}^2 + \frac{1}{2} \|\nabla \phi - \mathbf{q}\|_{0, \Pi}^2 + \frac{1}{2} \|\nabla \times \mathbf{q}\|_{0, \Pi}^2 + \|\lambda(\phi - \phi_s)\|_{0, \Gamma} \tag{24}$$

where the Lagrange multiplier defined on Γ is denoted by λ , with μ the associated weight function.

The least squares principles for functional Eq.(24) can be stated as:

Find $(\phi, \mathbf{q}, \lambda) \in \mathbf{X} \times M$ such that for all $(\psi, \mathbf{p}, \mu) \in \mathbf{X} \times M$

$$J(\phi, \mathbf{q}, \lambda; f, \phi_s) \leq J(\psi, \mathbf{p}, \mu; f, \phi_s) \tag{25}$$

where we use the spaces $\mathbf{X} = \{(\phi, \mathbf{q}) \in H^1(\Pi) \times \mathbf{H}^1(\Pi)\}$ and $M = \{\lambda \in H^{-1/2}(\Gamma)\}$.

This yields:

$$\begin{cases}
\text{Find } (\phi, \mathbf{q}, \lambda) \in \mathbf{X} \times M \text{ such that} \\
a((\phi, \mathbf{q}), (\psi, \mathbf{p})) + b((\psi, \mathbf{p}), \lambda) = l((\psi, \mathbf{p})) \quad \forall (\psi, \mathbf{p}) \in \mathbf{X} \\
b((\phi, \mathbf{q}), \mu) = g(\mu) \quad \forall \mu \in M
\end{cases} \tag{26}$$

where

$$a((\phi, \mathbf{q}), (\psi, \mathbf{p})) = ((-\nabla \cdot \mathbf{q}), (-\nabla \cdot \mathbf{p})) + ((\nabla \phi - \mathbf{q}), (\nabla \psi - \mathbf{p})) + ((\nabla \times \mathbf{q}), (\nabla \times \mathbf{p})) \quad (27)$$

$$b((\psi, \mathbf{p}), \lambda) = \langle \psi, \lambda \rangle \quad (28)$$

$$l((\psi, \mathbf{p})) = (f, (-\nabla \cdot \mathbf{p})) \quad (29)$$

$$g(\mu) = \langle \phi_s, \mu \rangle. \quad (30)$$

The solution of problem, Eq.(21), will be the restriction to Ω of the minimum, defined on domain Π , of functional Eq.(24).

4.3 Spectral Element approximation

The problem Eq.(26) can not be solved analytically and therefore it is necessary to use a numerical method to get approximated solution.

The spectral hp element method is a numerical technique for solving partial differential equations based on variational formulation of boundary and initial value problems [4][10][20]. The solution is represented by a finite number of basis functions. Spectral hp element method is based on higher order functions, which are locally defined over finite size parts of domain. The advantage of such kind of method respect to traditional finite element method is its exponential convergence property with the increasing of polynomial order p .

We proceed to define a discrete problem by choosing appropriate finite element subspaces for ϕ , each of the components of the vector valued function \mathbf{q} and Lagrange multiplier λ .

There are no restrictive compatibility conditions on the discrete spaces of the primary variables ϕ and \mathbf{q} , so we choose the same finite element subspace for each one. The only requirement on approximating spaces is that we choose continuous piecewise polynomials that are at least bi-linear in two dimensions or tri-linear in three dimensions.

Consider the two-dimensional case and let \mathcal{P}_h be a family of quadrilateral finite elements $\bar{\Omega}_e$ that make up the connected model $\bar{\Omega}_h$. We map $\bar{\Omega}_e$ to a bi-unit square $\hat{\Omega}_e = [-1,1] \times [-1,1]$, where (ξ, η) is a point in $\hat{\Omega}_e$. Over a typical element $\hat{\Omega}_e$, we approximate ϕ by the expression

$$\phi(\xi, \eta) = \sum_{i=1}^q \tilde{\phi}_i \varphi_i(\xi, \eta) \quad \text{in } \hat{\Omega}_e. \quad (31)$$

In modal expansion, φ_i are tensor products of the one-dimensional C^0 p -type hierarchical basis

Fictitious Domain with Least-Squares Spectral Element Method to Explore Geometric Uncertainties by Chaos Collocation

$$\psi_p = \begin{cases} \frac{1-\xi}{2} & \text{for } p=0 \\ \frac{1-\xi}{2} \frac{1+\xi}{2} P_{p-1}^{\alpha,\beta} & \text{for } 0 < p < P, P \geq 1 \\ \frac{1+\xi}{2} & \text{for } p=P \end{cases} \quad (32)$$

and $\tilde{\phi}_i$ are coefficients associated with each of the modes of hierarchical basis. In Eq.(32) $P_p^{\alpha,\beta}$ are the Jacobi polynomials of order p, in particular ultraspheric polynomials corresponding to the choice $\alpha = \beta$ with $\alpha = \beta = 1$. This choice is due to the considerations about the sparsity of the matrices we obtain discretizing the problem presented by [10].

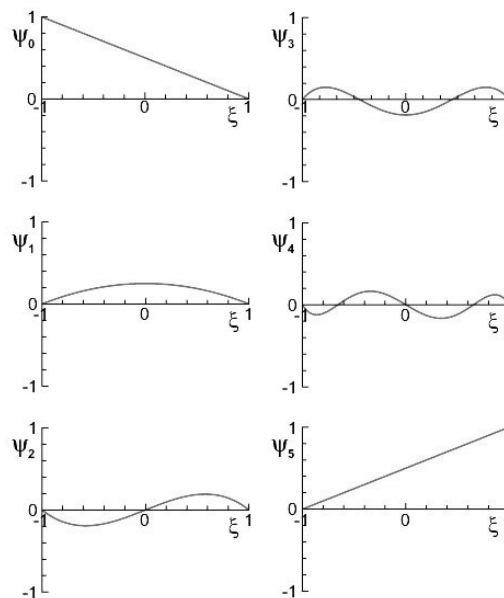

Figure 8: Shape of modal expansion modes for a polynomial order of P=5.

We approximate the components of the vector valued function \mathbf{q} on $\hat{\Omega}_e$ in similar manner as we did for ϕ in Eq.(31).

The approximation of Lagrange multipliers requires the discretization of the immersed boundary Γ into curvilinear one-dimensional elements $\bar{\Gamma}_e$, which are mapped to linear unit elements $\hat{\Gamma}_e = [-1,1]$. On these elements the function λ is approximated by the expression

$$\lambda(\xi) = \sum_{i=1}^q \tilde{\lambda}_i \psi_i(\xi) \quad \text{on } \hat{\Gamma}_e \quad (33)$$

where ψ_i are defined in Eq.(32) and $\tilde{\lambda}_i$ are the coefficients associated with expansion modes of function λ .

Let us remark the choice of Lagrange multipliers discrete space is not independent by the discrete spaces of variables ϕ and \mathbf{q} . To ensure the convergence of the solution of discretized model to that one of the continuous problem, the Ladyzhenskaja-Babuska-Brezzi (LBB)-condition has to be satisfied:

$$\sup_{\psi_{hp} \in H_{hp}^1(\Pi)} \frac{\int_{\Gamma} \mu_{HP} \psi_{hp} ds}{\|\psi_{hp}\|_H(\Pi)} \geq \bar{\beta} \|\mu_{HP}\|_M \quad \forall \mu_{HP} \in M_{HP} \quad (34)$$

for some $\bar{\beta} > 0$ independent of hp and HP .

In this way we proceed to generate a system of linear algebraic equations at element level. The integrals in these equations are evaluated using Gauss-Legendre quadrature rules. The global system of equations is assembled from the element contributions using the direct summation approach. The assembled system of equations can be written as

$$\begin{pmatrix} \mathbf{A} & \mathbf{B}^T \\ \mathbf{B} & \mathbf{0} \end{pmatrix} \begin{Bmatrix} \tilde{\mathbf{y}} \\ \tilde{\lambda} \end{Bmatrix} = \begin{Bmatrix} \mathbf{f} \\ \mathbf{g} \end{Bmatrix} \quad (35)$$

where $\tilde{\mathbf{y}}$ are the modal unknown coefficients associated with ϕ and \mathbf{q} , $\tilde{\lambda}$ are the modal unknown coefficients associated with λ , \mathbf{A} is the least squares matrix, \mathbf{B} is the matrix coupling the primal variables ϕ and \mathbf{q} and the Lagrange multiplier λ , \mathbf{f} is the load vector and \mathbf{g} is the constraint vector. To solve the system Eq.(35) we use a direct method. Note that the information on the geometry of domain is encoded only in \mathbf{B} and \mathbf{g} , not in \mathbf{A} or \mathbf{f} . So if we want to solve the same heat conduction equation on a different domain Ω we have just to calculate again the matrix \mathbf{B} and the vector \mathbf{g} , because \mathbf{A} and \mathbf{f} will not change.

4.4 Numerical example

We solve the convection-diffusion equation

$$-\Delta\phi + \{\mathbf{1}\}^T \cdot \nabla\phi = f(x, y) \quad (36)$$

on pentagonal domain Ω shown in Figure 9. On the boundary Γ Robin constraints have been imposed. According to Method of Manufactured Solutions [25], the source term $f(x, y)$ and the boundary constraints are such that solution is the function $\phi : \mathfrak{R}^2 \rightarrow \mathfrak{R}$, so defined:

$$\phi(x, y) = -(x^2 + y^2) + 1 + e^{xy}. \quad (37)$$

Fictitious Domain with Least-Squares Spectral Element Method to Explore Geometric Uncertainties by Chaos Collocation

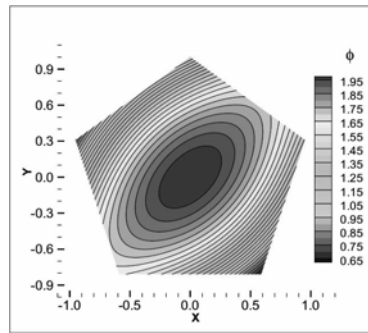

Figure 9: Function ϕ , solution of problem Eq.(36).

The fictitious domain considered is a square $\Pi = [-1.1, 1.1] \times [-1.0, 1.2]$, containing Ω . In order to demonstrate the accuracy of the method, several numerical grids have been used for calculations, as shown in Figure 10. Computational domain Π has been divided into four first and twenty-five after quadrilateral finite elements. The immersed boundary Γ has been discretized into ten and fifty linear elements.

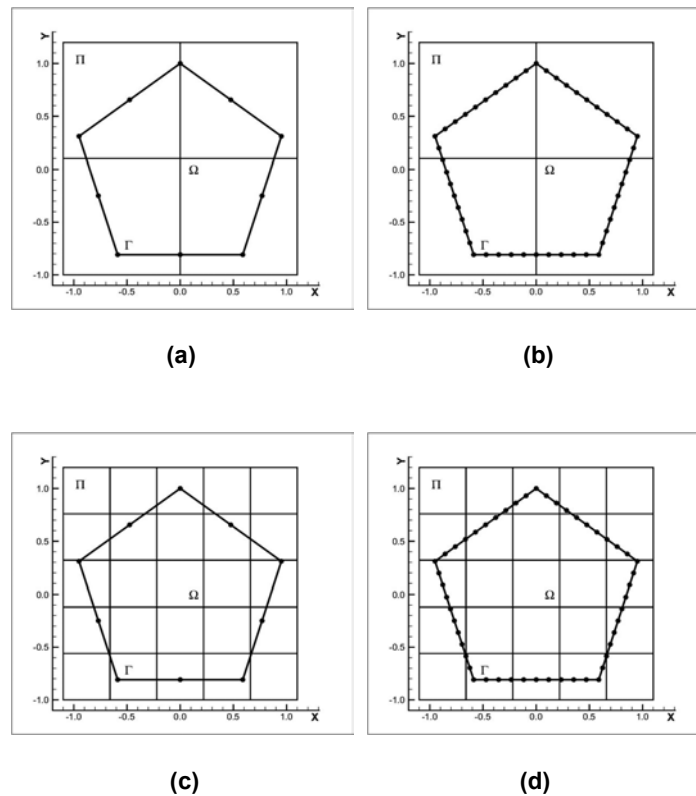

Figure 10: Numerical grids used for calculations. The model of domain Π consists of: (a) four quadrilateral spectral elements with ten immersed boundary elements, (b) four quadrilateral spectral elements with fifty immersed boundary elements, (c) twenty-five quadrilateral spectral elements with ten immersed boundary elements, (d) twenty-five quadrilateral spectral elements with fifty immersed boundary elements.

In Figure 11 the convergence of ϕ is shown as function of the expansion order of domain in a linear-logarithmic scale. Each curve corresponds to a different expansion order of Lagrange multipliers. These

curves are characterized by a minimum. We can observe if the number of immersed linear elements is low the curves with crescent expansion order move toward lower errors, on the contrary if the number of immersed linear elements is high the curves move toward higher errors. Interpolating the minimum values reached for each expansion order of domain p the convergence to exact solution is spectral. This behaviour depends on LBB-condition. The interpolating curve is pretty the same if we consider an identical discretization of domain Π , modifying just the Lagrange multiplier number of elements. Another remark is that the convergence of the interpolating curve is faster refining the discretized model of computational domain Π .

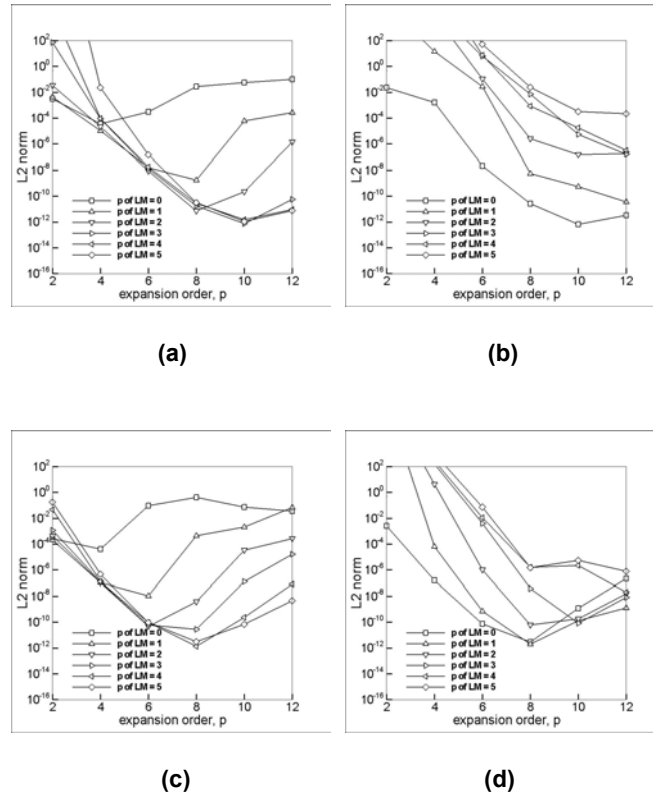

Figure 11: Convergence of the function ϕ to the exact solution of problem Eq.(36) in the L_2 -norm. Numerical solution obtained with: (a) h discretization of fictitious domain shown in Figure 10 (a), (b) h discretization of fictitious domain shown in Figure 10 (b), (c) h discretization of fictitious domain shown in Figure 10 (c), (d) h discretization of fictitious domain shown in Figure 10 (d).

5.0 THE DETERMINISTIC FORMULATION OF THE STOCHASTIC FICTITIOUS DOMAIN PROBLEM

Let $\theta \in \Theta$ be a random realization drawn from a complete probability space (Θ, \mathcal{A}, P) , whose event space Θ generates its σ -algebra $\mathcal{A} \subset 2^\Theta$ and is characterized by a probability measure P . For all $\theta \in \Theta$, let $\Omega(\theta) \subset \mathbb{R}^d$ be a d -dimensional random domain bounded by boundary $\Gamma(\theta)$. We consider the following stochastic boundary value problem: for P-almost everywhere in Θ , find a stochastic solution $\phi : \overline{\Omega}(\theta) \rightarrow \mathbb{R}$ such that:

**Fictitious Domain with Least-Squares Spectral Element
Method to Explore Geometric Uncertainties by Chaos Collocation**

$$\begin{aligned} -\Delta\phi &= f & \text{in } \Omega(\theta) \\ \phi &= \phi_s & \text{on } \Gamma(\theta) \end{aligned} \quad (38)$$

where f is the source term and ϕ_s is the prescribed value of ϕ on stochastic boundary $\Gamma(\theta)$. This problem is chosen only for notational simplicity.

We proceed by replacing the problem, Eq.(38), with its first-order equivalent system:

Find $\phi(\mathbf{x}, \theta)$ and $\mathbf{q}(\mathbf{x}, \theta)$ such that

$$\begin{aligned} -\nabla \cdot \mathbf{q} &= f & \text{in } \Omega(\theta) \\ \nabla\phi - \mathbf{q} &= 0 & \text{in } \Omega(\theta) \\ \nabla \times \mathbf{q} &= 0 & \text{in } \Omega(\theta) \\ \phi &= \phi_s & \text{on } \Gamma(\theta) \end{aligned} \quad (39)$$

where \mathbf{q} is the flux of scalar function ϕ .

The L^2 least-squares functional associated with first-order equivalent system formulation is given by

$$J(\phi, \mathbf{q}; f) = \frac{1}{2} \|\nabla \cdot \mathbf{q} - f\|_{0, \Omega(\theta)}^2 + \frac{1}{2} \|\nabla\phi - \mathbf{q}\|_{0, \Omega(\theta)}^2 + \frac{1}{2} \|\nabla \times \mathbf{q}\|_{0, \Omega(\theta)}^2 \quad (40)$$

and its Fictitious Domain implementation will be:

$$J(\phi, \mathbf{q}, \lambda; f, \phi_s) = \frac{1}{2} \|\nabla \cdot \mathbf{q} - f\|_{0, \Pi}^2 + \frac{1}{2} \|\nabla\phi - \mathbf{q}\|_{0, \Pi}^2 + \frac{1}{2} \|\nabla \times \mathbf{q}\|_{0, \Pi}^2 + \|\lambda(\phi - \phi_s)\|_{0, \Gamma(\theta)} \quad (41)$$

where the Lagrange multiplier defined on Γ is denoted by λ , with μ the associated weight function.

The least squares principles for functional Eq.(41) can be stated as:

Find $(\phi, \mathbf{q}, \lambda) \in \mathbf{X} \times M(\theta)$ such that for all $(\psi, \mathbf{p}, \mu) \in \mathbf{X} \times M(\theta)$

$$J(\phi, \mathbf{q}, \lambda; f, \phi_s) \leq J(\psi, \mathbf{p}, \mu; f, \phi_s) \quad (42)$$

where we use the spaces $\mathbf{X} = \{(\phi, \mathbf{q}) \in H^1(\Pi) \times \mathbf{H}^1(\Pi)\}$ and $M(\theta) = \{\lambda \in H^{-1/2}(\Gamma(\theta))\}$.

This yields:

$$\begin{cases} \text{Find } (\phi, \mathbf{q}, \lambda) \in \mathbf{X} \times M(\theta) \text{ such that} \\ a((\phi, \mathbf{q}), (\psi, \mathbf{p})) + b((\psi, \mathbf{p}), \lambda) = l((\psi, \mathbf{p})) \quad \forall (\psi, \mathbf{p}) \in \mathbf{X} \\ b((\phi, \mathbf{q}), \mu) = g(\mu) \quad \forall \mu \in M(\theta) \end{cases} \quad (43)$$

where

$$a((\phi, \mathbf{q}), (\psi, \mathbf{p})) = \int_{\Pi} (-\nabla \cdot \mathbf{q})(-\nabla \cdot \mathbf{p}) d\Pi + \int_{\Pi} (\nabla \phi - \mathbf{q}) \cdot (\nabla \psi - \mathbf{p}) d\Pi + \int_{\Pi} (\nabla \times \mathbf{q}) \cdot (\nabla \times \mathbf{p}) d\Pi \quad (44)$$

$$b((\psi, \mathbf{p}), \lambda) = \int_{\Gamma(\theta)} \psi \lambda d\Gamma \quad (45)$$

$$l((\psi, \mathbf{p})) = \int_{\Pi} f(-\nabla \cdot \mathbf{p}) d\Pi \quad (46)$$

$$g(\mu) = \int_{\Gamma(\theta)} \phi_s \mu d\Gamma. \quad (47)$$

The solution of problem, Eq.(38), will be the restriction to $\Omega(\theta)$ of the minimum, defined on domain Π , of functional Eq.(42).

The saddle point problem Eq.(43) has a stochastic formulation. We assume that the boundary $\Gamma(\mathbf{x}, \theta)$ of $\Omega(\mathbf{x}, \theta) \subset \Pi(\mathbf{x})$ depends on θ via n mutually independent real random variables $\xi_i(\theta)$ with zero mean and unit variance with respect to a density function ρ defined on some interval $I \in \mathfrak{R}$, so that $\mathbf{I} = I^n$. Referring to Eq.(6) we can write the stochastic process as

$$\Gamma(\mathbf{x}, \theta) \cong \Gamma^*(\mathbf{x}, \theta) = \sum_{i=0}^N \Gamma_i(\mathbf{x}) H_i(\xi). \quad (48)$$

Substituting the polynomial Chaos series into Eq.(43) we obtain

$$\left\{ \begin{array}{l} \text{Find } (\phi^*, \mathbf{q}^*, \lambda^*) \in L^2_{\rho}(\mathbf{I}; \mathbf{X}) \times L^2_{\rho}(\mathbf{I}; M^*) \text{ such that} \\ a((\phi^*, \mathbf{q}^*), (\psi^*, \mathbf{p}^*)) + b((\psi^*, \mathbf{p}^*), \lambda^*) = l((\psi^*, \mathbf{p}^*)) \quad \forall (\psi^*, \mathbf{p}^*) \in L^2_{\rho}(\mathbf{I}; \mathbf{X}) \\ b((\phi^*, \mathbf{q}^*), \mu^*) = g(\mu^*) \quad \forall \mu^* \in L^2_{\rho}(\mathbf{I}; M^*) \end{array} \right. \quad (49)$$

where

$$\phi^*(\mathbf{x}, \theta) = \sum_{i=0}^N \phi_i(\mathbf{x}) H_i(\xi) \quad (50)$$

$$\mathbf{q}^*(\mathbf{x}, \theta) = \sum_{i=0}^N \mathbf{q}_i(\mathbf{x}) H_i(\xi) \quad (51)$$

$$\lambda^*(\mathbf{x}, \theta) = \sum_{i=0}^N \lambda_i(\mathbf{x}) H_i(\xi) \quad (52)$$

and $M^* = \{\lambda^* \in H^{-1/2}(\Gamma^*)\}$. In this way we divide the random process into a deterministic part and a stochastic part. To solve Eq.(49) the method of Weighted Residuals is adopted, in particular the

Fictitious Domain with Least-Squares Spectral Element Method to Explore Geometric Uncertainties by Chaos Collocation

Collocation projection. This formulation gives a linear system of decoupled equations equivalent to solving a deterministic problem at each grid point:

$$\begin{cases} \text{Find } (\phi_i, \mathbf{q}_i, \lambda_i) \in \mathbf{X} \times M_i \text{ such that} \\ a((\phi_i, \mathbf{q}_i), (\psi_i, \mathbf{p}_i)) + b((\psi_i, \mathbf{p}_i), \lambda_i) = l((\psi_i, \mathbf{p}_i)) \quad \forall (\psi_i, \mathbf{p}_i) \in \mathbf{X} \\ b((\phi_i, \mathbf{q}_i), \mu_i) = g(\mu_i) \quad \forall \mu_i \in M_i \end{cases} \quad (53)$$

with $i = 0, \dots, N$ where $M_i = \{\lambda_i \in H^{-1/2}(\Gamma_i)\}$. To reconstruct the stochastic solution $\phi(\mathbf{x}, \theta)$ the equations Eq.(12) and Eq.(13) are used.

6.0 APPLICATIONS OF CHAOS COLLOCATION METHOD WITH FICTITIOUS DOMAIN APPROACH

6.1 One-dimensional problem

To validate the proposed methodology, we consider the one-dimensional problem defined on stochastic domain given in Eq.(17). The analytic solution of this problem, if the length L of domain is a deterministic variable, writes as:

$$\phi(x) = \frac{\phi_0}{\sqrt{k}} \frac{(1 + \sqrt{k})e^{\sqrt{k}L} e^{-\sqrt{k}x} + (1 - \sqrt{k})e^{-\sqrt{k}L} e^{\sqrt{k}x}}{(1 + \sqrt{k})e^{\sqrt{k}L} - (1 - \sqrt{k})e^{-\sqrt{k}L}}. \quad (54)$$

As we know the analytic function $\phi(x)$, given the uncertainty on the length L , we can compute the probability density function $pdf(\phi)$, using the formulation [27]:

$$\begin{aligned} Z &= f(X) \\ X &\text{ random variable with } p_X(x) \\ p_Z(z) &= \frac{p_X(x_1)}{|f'(x_1)|} + \frac{p_X(x_2)}{|f'(x_2)|} + \dots + \frac{p_X(x_n)}{|f'(x_n)|} \end{aligned} \quad (55)$$

where x is the random variable with distribution $p_X(x)$, Z is the random output variable and x_1, \dots, x_n are the inverses of Z ($x_i = f^{-1}(z)$).

To verify the accuracy of the presented methodology, the coupling of Chaos Collocation and Fictitious Domain for geometric uncertainties, we compare the results obtained by proposed method to the analytical $pdf(\phi)$ in three points ($x_1=0.0$, $x_2=45.0$, $x_3=90.0$). In [36] it has been already demonstrated as the Monte Carlo method, the methodology mainly used for studying of uncertainties, is not as accurate as Polynomial Chaos approximation and with higher computational cost, so we will not consider Monte Carlo method for comparison.

Fictitious Domain with Least-Squares Spectral Element Method to Explore Geometric Uncertainties by Chaos Collocation

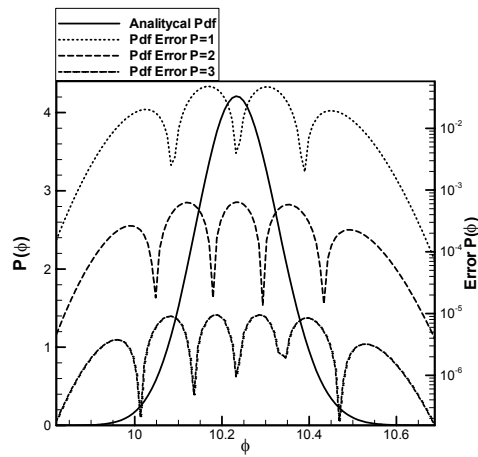

Figure 12: Solution of problem Eq.(17): analytical $pdf(\phi)$ and comparison of error respect to analytical $pdf(\phi)$ of Chaos Collocation $pdf(\phi)$ with different expansion order P in $x_1=0.0$.

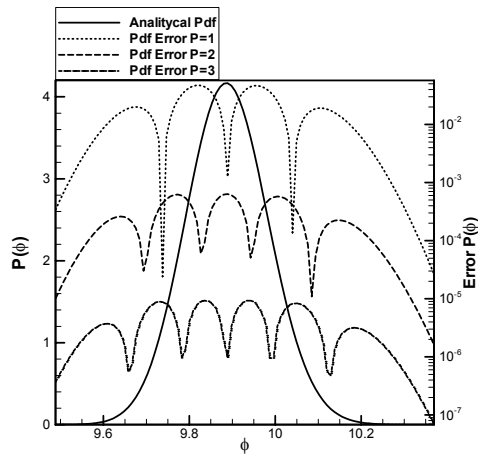

Figure 13: Solution of problem Eq.(17): analytical $pdf(\phi)$ and comparison of error respect to analytical $pdf(\phi)$ of Chaos Collocation $pdf(\phi)$ with different expansion order P in $x_2=45.0$.

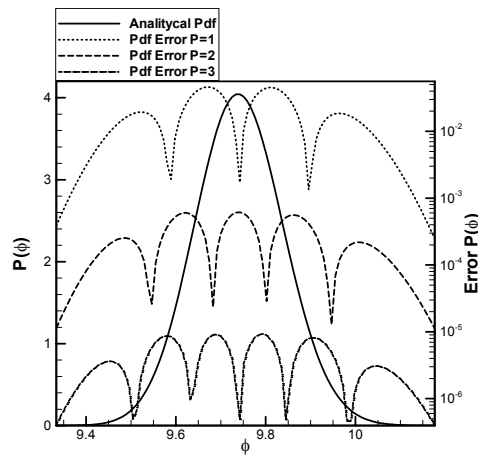

Figure 14: Solution of problem Eq.(17): analytical $pdf(\phi)$ and comparison of error respect to analytical $pdf(\phi)$ of Chaos Collocation $pdf(\phi)$ with different expansion order P in $x_3=90.0$.

Fictitious Domain with Least-Squares Spectral Element Method to Explore Geometric Uncertainties by Chaos Collocation

In Figure 12, Figure 13 and Figure 14 the accuracy of pdf obtained by our approach is shown for increasing polynomial order. It is evident the accuracy is pretty much the same in different points of domain and the accuracy improves visibly increasing the polynomial order from $P=1$ to $P=3$.

In Figure 15 the evolution of temperature is plotted in error bars, with the line centered at the mean value $E(\phi)$ and the length of uncertainty bars equal to two standard deviations, which is the interval containing 99% of all possible values. There is an increase of uncertainty bars with growing abscissa and a corresponding decrease of mean value of temperature. This behaviour is due to higher closeness to the uncertain point ($L = N(100,1)$) with growing abscissa and a greater influence of uncertainty to points closer to that one.

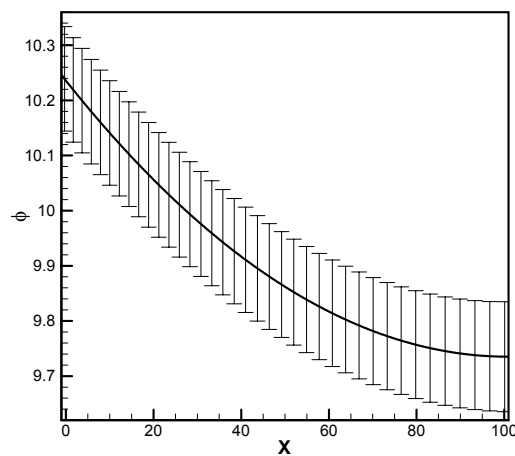

Figure 15: Mean function $E(\phi)$ and uncertainty bars $E(\phi) \pm \sigma$ of problem Eq.(17).

This example demonstrates the capability of developed methodology, so we can use it to study a two-dimensional problem with geometric tolerance.

6.2 Two-dimensional problem

In this section we consider the stationary heat conduction in an electronic chip [35], subject to geometric tolerances:

$$-\nabla \cdot (k\nabla T) = f \quad \text{in } \Omega(\theta) \quad (56)$$

with $k=1$ and $f=0$. The stochastic domain is shown in Figure 16. The domain dimensions are deterministic parameters except thickness of cavity L which has a normal distribution $N(0.6, 0.01)$. The boundary of domain consists of four segments: the top Γ_T , the bottom Γ_B , the two sides Γ_S and the boundaries of the cavity Γ_C . Adiabatic boundary conditions are prescribed on Γ_B and Γ_S . The cavity boundary Γ_C is exposed to heat flux $q_b|_{\Gamma_C} = 1$. On the top Γ_T is maintained at constant temperature $T = 0$.

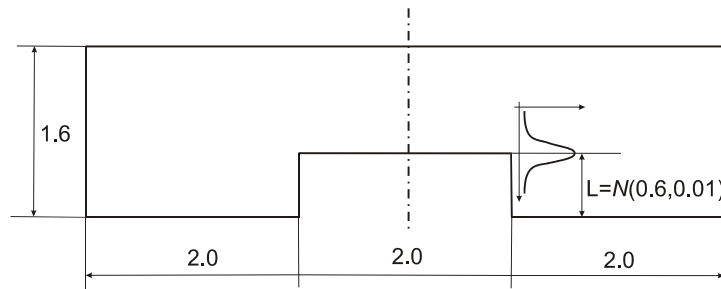

Figure 16: Stochastic domain of stationary heat conduction problem Eq.(56) in an electronic chip.

Figure 17 shows the computational domain which differs from chip geometry and in particular contains it, according to Fictitious Domain approach. The fictitious domain has been discretized into 15 spectral elements of order 8.

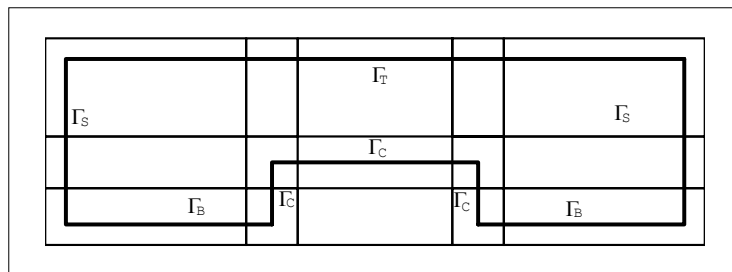

Figure 17: Schematic of the computational fictitious domain of stationary heat conduction problem Eq.(56) under study.

We are interested in the stochastic solution at the points of domain. Actually we solve the heat conduction problem on all the points of fictitious domain and we associate to each point the probability of belonging to the chip, as shown in Figure 18 for the top left corner of the cavity. In this way we have the mean and the standard deviation of temperature due to geometric tolerance even in points which do not really belong to chip, but as we associate a probability of belonging the results are still significant.

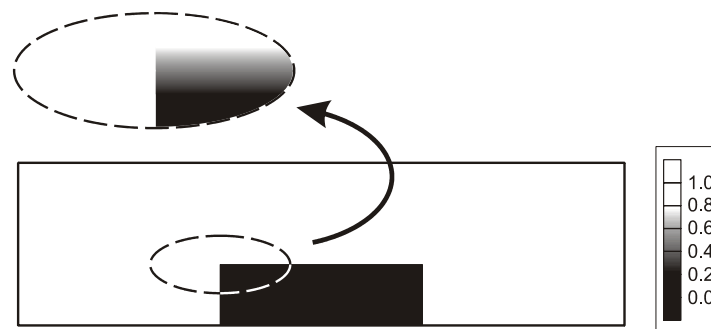

Figure 18: Probability of points of fictitious domain to belong to chip.

We verify the behaviour of accuracy of the method varying the polynomial order of Polynomial Chaos approximation. In Figure 19 and Figure 20 the comparison of mean solution and standard deviation respectively along the section $x=0$, which corresponds to the axis of symmetry of the electronic chip, are shown, obtained with polynomial order $P=1$, $P=2$, $P=3$. The curves of mean coincide, but we have

Fictitious Domain with Least-Squares Spectral Element Method to Explore Geometric Uncertainties by Chaos Collocation

different accuracy of standard deviation with increasing P . For values higher of 3 there are not significant variations of solution, so there is no need to increase P further more, taking into account of computational cost, too.

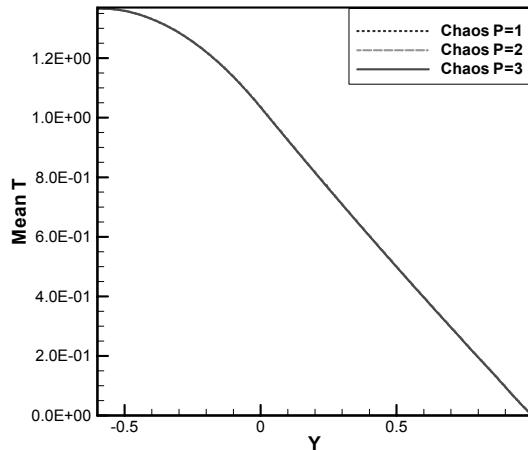

Figure 19: Comparison of mean solution along the section $x=0$ obtained by Chaos Collocation with polynomial order $P=1$, $P=2$, $P=3$.

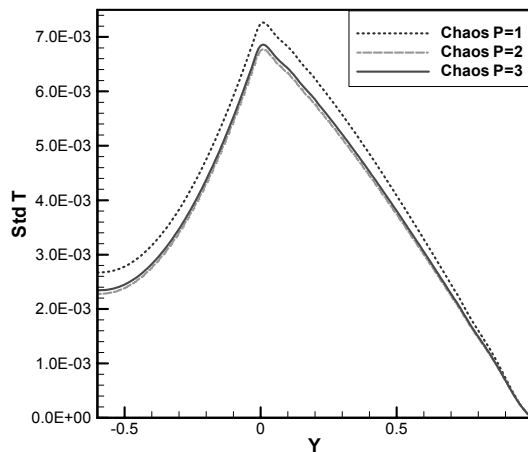

Figure 20: Comparison of standard deviation along the section $x=0$ obtained by Chaos Collocation with polynomial order $P=1$, $P=2$, $P=3$.

Figure 21 shows the contours of mean field of temperature and Figure 22 shows the contours of standard deviation. It is seen that the largest output uncertainty, indicated by the standard deviation, occurs near the top of the cavity, whose position is subject to probability distribution. In fact this is the result we expected according to results obtained studying one-dimensional problem in section 6.0. This behaviour is due to greater influence of uncertainty to points closer to that one.

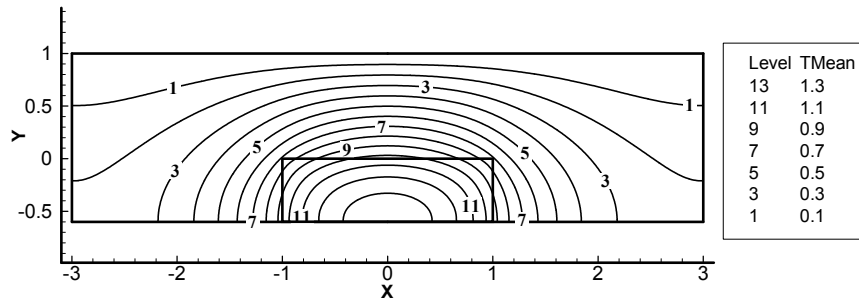

Figure 21: Contours of temperature distributions in the electronic chip: mean field.

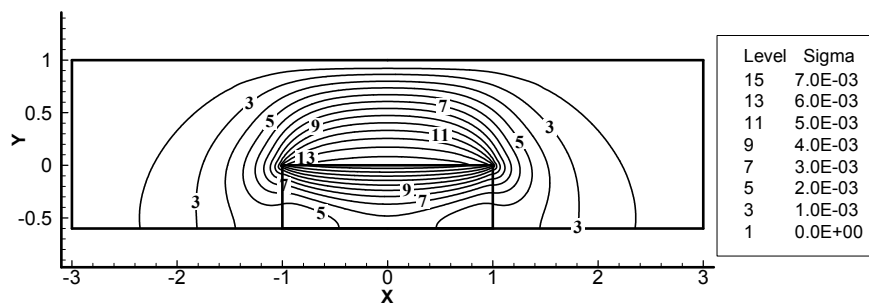

Figure 22: Contours of temperature distributions in the electronic chip: standard deviation field.

7.0 CONCLUSIONS

In this paper we presented the Chaos Collocation method employing a Fictitious Domain approach to study geometric tolerances. In particular the method has been applied to one- and two-dimensional elliptic problems with geometric uncertainties in order to demonstrate the accuracy and convergence of the methodology.

A big advantage of proposed method is that it is non-intrusive, which means existing deterministic solvers can be used without any internal modification. In this way we get a simplification of computational process management. A Least-Squares Spectral Element method has been employed for the analysis of deterministic differential problems obtained by Collocation projection. To avoid remeshing of computational domain for each one of differential problems, Fictitious Domain approach is introduced. Its main advantage lies in the fact that only one Cartesian mesh, that represents the enclosure, needs to be generated.

Excellent accuracy properties of the method are demonstrated by numerical experiments. We have compared it to analytical solution, considering a one-dimensional elliptic problem with uncertainties on domain length. The algorithm has been finally used to solve a two-dimensional heat conduction problem with random domain.

Several issues need to be addressed:

- Comparison between Chaos Polynomial and Chaos Collocation methods: in case of multiple uncertain parameters the number of coefficients is lower using an intrusive approach, but it is evident the difficulty to implement it inside the solver; taking in account of both these remarks, it would be interesting evaluate computational benefits of the two approaches;

Fictitious Domain with Least-Squares Spectral Element Method to Explore Geometric Uncertainties by Chaos Collocation

- problems with multi dimensional stochastic domain by Chaos Collocation: the choice of collocation points in case of multiple uncertain parameters is not unique, so an effective criteria should be given;
- fluid dynamic problems defined on stochastic domain: the Fictitious Domain approach has been implemented just to solve advection-diffusion equation; even if the theory is simple to be extended to fluid dynamic case, the implementation and validation of the methodology have still to be achieved.

ACKNOWLEDGEMENT

This work was partially supported by the project NODESIM-CFD *Non-Deterministic Simulation for CFD-based Design Methodologies* funded by the European Community represented by the CEC, Research Directorate-General, in the 6th Framework Programme, under Contract No. AST5-CT-2006-030959.

8.0 REFERENCES

- [1] Abramowitz, M.; Stegun, I.A. (1972). Handbook of mathematical functions. Dover publications, New York.
- [2] Askey, A.; Wilson, J.A. (1985). Some basic hypergeometric orthogonal polynomials that generalize Jacobi polynomials. Mem. Amer. Math. Soc., vol. 319.
- [3] Blith, M.; Pozrikidis, C. (2003). Heat conduction across irregular and fractal-like surfaces. International Journal of Heat and Mass Transfer, vol. 46, pp. 1329-1339.
- [4] Gerritsma, M.; Maerschalck, B.D. (2005). The least-squares spectral element method. In *CFD-High Order Methods*, Bruxelles. Lectures Series Von Karman Institute.
- [5] Glowinski, R.; Pan, T.-W.; Hesla, T.I.; Joseph, D. (1999). A distributed Lagrange multiplier/fictitious domain method for particulate flows. Int. J. Multiphase Flow, vol. 25, pp. 755-794.
- [6] Glowinski, R.; Pan, T.-W.; Hesla, T.I.; Joseph, D.D.; Periaux, J. (2000). A distributed Lagrange multiplier/fictitious domain method for the simulation of flows around moving rigid bodies: Application to particulate flow. Comp. Meth. Appl. Mech. Eng., vol. 184, pp. 241-268.
- [7] Haslinger, J.; Maitre, J.F.; Tomas, L. (2001). Fictitious domains methods with distributed Lagrange multipliers. Part I : application to the solution of elliptic state problems. Mathematical Models and Methods In Applied Sciences, vol. 11, no. 3, pp. 521-547.
- [8] Hosder, S.; Walters, R.; Perez, R. (2006). A Non-Intrusive Polynomial Chaos Method For Uncertainty Propagation in CFD Simulation. In *44th AIAA Aerospace Science Meeting and Exhibit, 9-12 January 2006*, Reno, Nevada.
- [9] Joly, P.; Rhaouti, L. (1999). Domaines fictifs, elements finis $H(\text{div})$ et condition de Neumann: le probleme de la condition inf-sup. C.R. Acad. Sci. Paris, vol. 328, no. 12, pp. 1225-1230.
- [10] Karniadakis, G.E.; Sherwin, S.J. (1999). Spectral/hp Element Methods for CFD. Oxford University Press, Oxford.
- [11] Lin, G.; Su, C.; Karniadakis, G. (2006). Modelling Random Roughness in Supersonic Flow Past a Wedge. In *44th AIAA Aerospace Science Meeting and Exhibit, 9-12 January 2006*, Reno, Nevada.

- [12] Lin, G.; Wan, X.; Su, C.; Karniadakis, G. (2007). Stochastic Computational Fluid Mechanics. *Computing in Science and Engineering*, vol. 9, no. 2, pp. 21-29.
- [13] Loeven, G.; Witteveen, J.; Bijl, H. (2006). Efficient uncertainty quantification using a two-step approach with Chaos Collocation. In *ECCOMAS CFD*.
- [14] Loeven, G.; Witteveen, J.; Bijl, H. (2007). Probabilistic Collocation: An Efficient Non-Intrusive Approach For Arbitrarily Distributed Parametric Uncertainties. In *45th AIAA Aerospace Science Meeting and Exhibit, 8-11 January 2007*, Reno, Nevada.
- [15] Makinen, R. A.E.; Rossi, T.; Toivanen, J. (2000). A moving mesh fictitious domain approach for shape optimization problems. *Mathematical Modelling and Numerical Analysis*, vol. 34, no.1, pp. 31-45.
- [16] Mathelin, L.; Hussaini, Y. (2003). A Stochastic Collocation Algorithm for Uncertainty Analysis. *NASA/CR-2003-212153*.
- [17] Maury, B. (2001). A Fat Boundary Method for the Poisson Equation in a Domain with Holes. *J. of Sci. Computing*, vol. 16, no. 3, pp. 319-339.
- [18] Parussini, L. (2007). Fictitious domain approach for spectral/hp element method. *CMES Computer Modeling in Engineering and Sciences*, vol. 17, no. 2, pp. 95-114.
- [19] Pontaza, J.P. (2007). A spectral element least-squares formulation for incompressible Navier-Stokes flows using triangular nodal elements. *Journal of Computational Physics*, vol. 221, pp. 649-665.
- [20] Pontaza, J.P.; Reddy, J.N. (2003). Spectral/hp least-squares finite element formulation for Navier-Stokes equations. *Journal of Computational Physics*, vol. 190, pp. 523-549.
- [21] Pontaza, J.P.; Reddy, J.N. (2004). Space-time coupled spectral/hp least-squares finite element formulation for the incompressible Navier-Stokes equations. *Journal of Computational Physics*, vol. 197, pp. 418-459.
- [22] Proot, M. M.J.; Gerritsma, M.I. (2002). A least-squares spectral element formulation for the stokes problem. *Journal of Scientific Computing*, vol. 17, pp. 285-296.
- [23] Proot, M. M.J.; Gerritsma, M.I. (2005). Application of least-squares spectral element method using Chebyshev polynomials to solve the incompressible Navier-Stokes equations. *Numerical Algorithms*, vol. 38, pp. 155-172.
- [24] Ramiere, I.; Angot, P.; Belliard, M. (2005). Fictitious domain methods to solve convection-diffusion problems with general boundary conditions. In *17th Computational Fluid Dynamics Conference - AIAA*, pp. 2005-4709, Toronto, Canada.
- [25] Roache, P. J. (2002). Code Verification by the Method of Manufactured Solutions. *Journal of Fluids Engineering*, vol. 124, n. 1, pp. 4-10
- [26] Rossi, T.; Toivanen, J. (1999). Parallel Fictitious Domain Method for a Nonlinear Elliptic Neumann Boundary Value Problem. *Numerical linear algebra with applications*, vol. 6, no. 1, pp. 51-60.
- [27] Rotondi, A.; Pedroni, P.; Pievatolo, A. (2001). *Probabilità Statistica e Simulazione*. Springer.
- [28] Schoutens, W. (2000). *Stochastic Processes and Orthogonal Polynomial*. Springer, 5 edition.

Fictitious Domain with Least-Squares Spectral Element Method to Explore Geometric Uncertainties by Chaos Collocation

- [29] Stenberg, R. (1995). On some techniques for approximating boundary conditions in the finite element method. *Journal of Computational and Applied Mathematics*, vol. 63, pp. 139-148.
- [30] Wan, X.; Karniadakis, G. (2006). Stochastic heat transfer in a grooved channel. *J. Fluid Mech.*, vol. 565, pp. 255-278.
- [31] Wiener, N. (1938). The homogeneous chaos. *Am. J. math.*, vol. 60, pp. 897-936.
- [32] Wiener, N. (1958). *Nonlinear Problems in Random Theory*. MIT Technology Press and John Wiley and Sons, New York.
- [33] Xiu, D.; Karniadakis, G.E. (2002). Modelling uncertainty in steady state diffusion problems via generalized polynomial chaos. *Computer methods in applied mechanics and engineering*, vol. 191, pp. 4927-4948.
- [34] Xiu, D.; Karniadakis, G.E. (2003). A new stochastic approach to transient heat conduction modelling with uncertainty. *International Journal of Heat and Mass Transfer*, vol. 46, pp. 4681-4693.
- [35] Xiu, D.; Karniadakis, G.E. (2003). Modelling uncertainties in flow simulation via generalized polynomial chaos. *Journal of Computational Physics*, vol. 187, pp. 137-167.
- [36] Xiu, D.; Tartakovsky, D.M. (2006). Numerical methods for differential equations in random domains. *SIAM J. Sci. Comput.*, vol. 28, no. 3, pp. 1167-1185.
- [37] Zienkiewicz, O.C.; Taylor, R.L. (2000). *The finite element method*. Oxford, 5 edition.

Paper No. 36**Discussor's Name: M. Hensch****Question:** Are you working on the effective choice of collocation points? What approaches are you using?**Author's Reply:** For problems with one uncertain parameter the collocation points are the roots of polynomial of order $p+1$. If we have multi-uncertain parameters, we will use the full-factorial of these roots.**Discussor's Name: A. Cunningham****Question:** Are your collocation points chosen on the basis of polynomial roots such as roots of Tchebycheff polynomials?**Author's Reply:** The collocation points are the roots of a Hermite polynomial (for Gaussian uncertainty) with order $p+1$, where p is the expansion order of the polynomial chaos approximation.